



HomeGlide Stairlift

FOR STRAIGHT STAIRCASES



Access BDD is one of Europe's leading suppliers of stairlifts, platform lifts and home lift solutions.

HomeGlide Stairlift

FOR STRAIGHT STAIRCASES

The HomeGlide stairlift range delivers a solution for all indoor straight staircase requirements and budgets. The HomeGlide and HomeGlide Extra are fitted onto your staircase and not your wall. This allows the lift to be installed quickly, easily and with minimal disruption to your home.

It is designed to glide effortlessly along an aluminium track, providing an attractive, elegant and discreet addition to your home. Built using the latest technology, the HomeGlide stairlift range can be fitted to almost all straight staircases as narrow as 740 mm.

1 It's all about you

The thick and luxurious padding ensures a firm and comfortable seat. The sisal colour of the upholstery is a neutral tone which will fit in every household. The upholstery is also fire retardant, liquid repellent and easy to clean. The HomeGlide is operated with an easy to use joystick which can also be removed to prevent unauthorised usage.

2 Compact and Discreet

The HomeGlide's design is simple, sturdy and above all satisfies your accessibility requirements. Remote control handsets allow the HomeGlide to park at either the top or bottom of the staircase, wherever is the most convenient for you. When not in use the HomeGlide is folded away to only 380 mm on any landing, out of the way of any other staircase users.

3 Safety

Your safety is of paramount importance to us. The HomeGlide stairlift is certified to machine directive 2006/42/EG and BS EN 81-40. During travel the retractable seat belt will keep you secure on the stairlift. If the lift encounters an obstacle it will safely come to a stop as a result of special safety edges on the drive unit. The stairlift is battery operated, which means you can still use it during a power cut.





The HomeGlide's aluminium rail has a slim design giving a modern and clean look.



I just love my HomeGlide stairlift! I had real difficulties climbing the stairs, but now I just sit in comfort on the stairlift, no more problems."



HomeGlide Extra Stairlift

AN ARRAY OF OPTIONS AND ENHANCEMENTS

Choosing to have the HomeGlide Extra means you receive all of the features and benefits of the HomeGlide with further options and upholstery selections to ensure the perfect fit in your home. The HomeGlide Extra proves to be the ultimate marriage of elegant design and hi-tech functionality for any straight staircase.

Linked footrest

As standard, the HomeGlide Extra comes with a linked footrest. This feature makes it almost effortless when unfolding the chair as the footrest is linked to the seat.

Ergonomically-shaped seat

Designed with ergonomic experts the HomeGlide Extra uses a seat which positively influences your posture while offering maximum comfort.

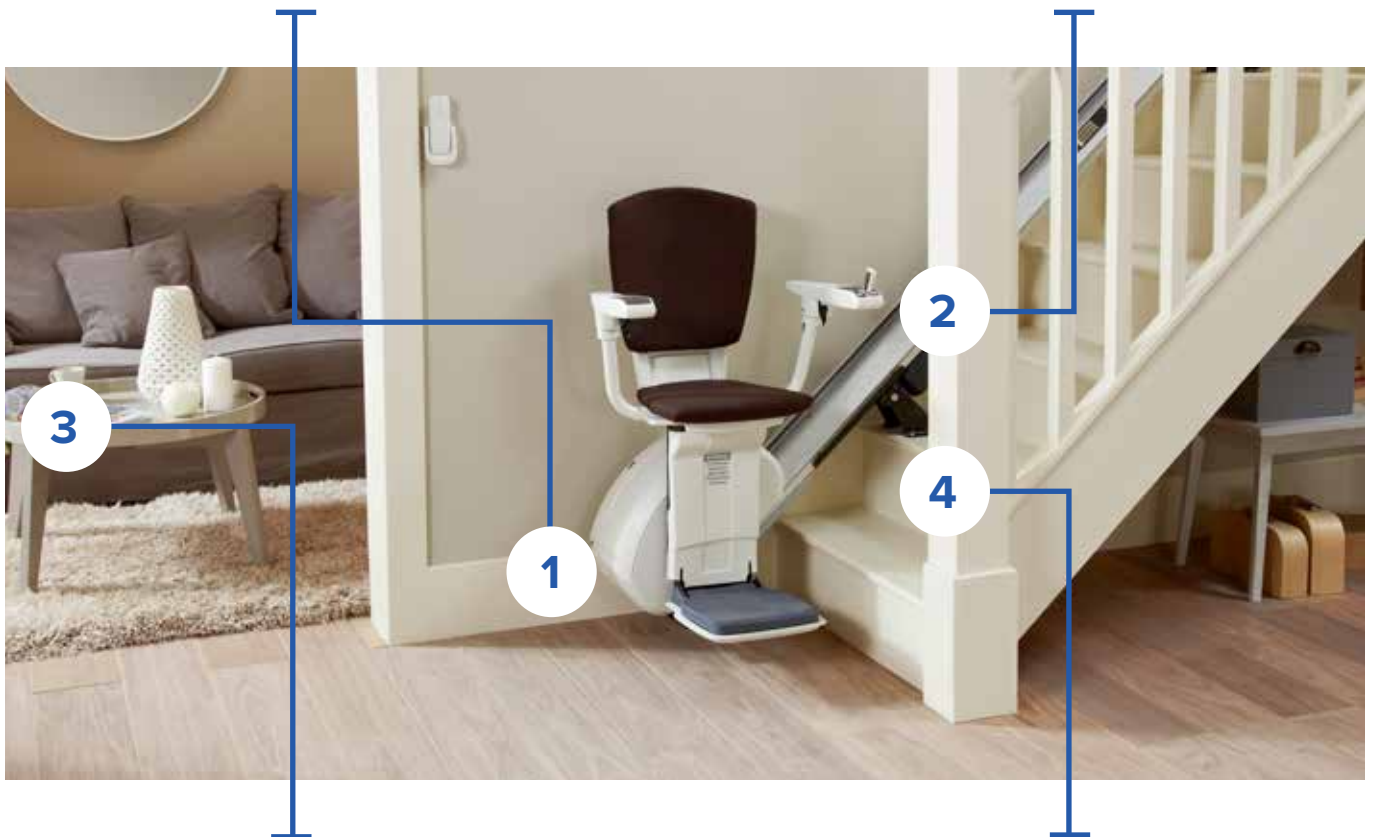

A world of choice

As well as the quality enhancements that come as standard with the HomeGlide Extra, there are a number of options available which include a wide array of upholstery colours. Choose from fabric and vinyl seat covers to match the style of your home and décor.

A greater sense of security

Your stairlift should make you feel safe. The HomeGlide Extra comes with a retractable seat belt and can be fitted with curved armrests to help keep you secure on the lift. It is also possible to fit the straight armrests if you would prefer this.



As standard, the HomeGlide Extra comes with a linked footrest.



Standard Options

IT'S ALL ABOUT YOU

When you choose a HomeGlide stairlift you ensure an ideal solution for your staircase. With a smooth aluminium track, this stairlift can be fitted to almost any straight staircase.

Automatic Powered Hinge



If you have an obstruction at the foot of the staircase you can choose to have an automatic powered hinge installed. Once you have used the stairlift it will return to the top of the stairs and the lower section of the rail will fold away, leaving the bottom of your staircase clear.

Maximum Weight Upgrade



As standard the HomeGlide will support weights of up to 125 kg. If required, this can be upgraded up to 146 kg.

Move between all levels of your home with maximum comfort and safety.





HomeGlide Extra Options

EVEN MORE CHOICE

With an added choice of upholstery and functionality options, HomeGlide Extra is an elegant and attractive addition to your home.

Upholstery

Vinyl:



Red



Grey



Maroon



Sisal

Fabric:



Dark Brown



Beige

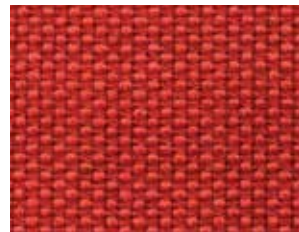

Red



Choose from fabric and vinyl seat covers to match the style of your home.



Powered Swivel Seat and Adjustable Seat Height



The HomeGlide Extra comes with a manual swivel seat as standard. Upgrading to the powered swivel seat allows you to turn the chair easily at the top or bottom landing by maintaining pressure on the joystick. This allows a safe exit from the chair as the lift automatically rotates away from the open staircase.

There are four different seat heights to choose from providing you with the most comfortable seating position possible. The footrest lies just 97 mm from the floor, making getting on and off the seat as easy as possible.

Armrest

Straight



Curved



Technical Specification

CERTIFIED TO THE HIGHEST STANDARDS

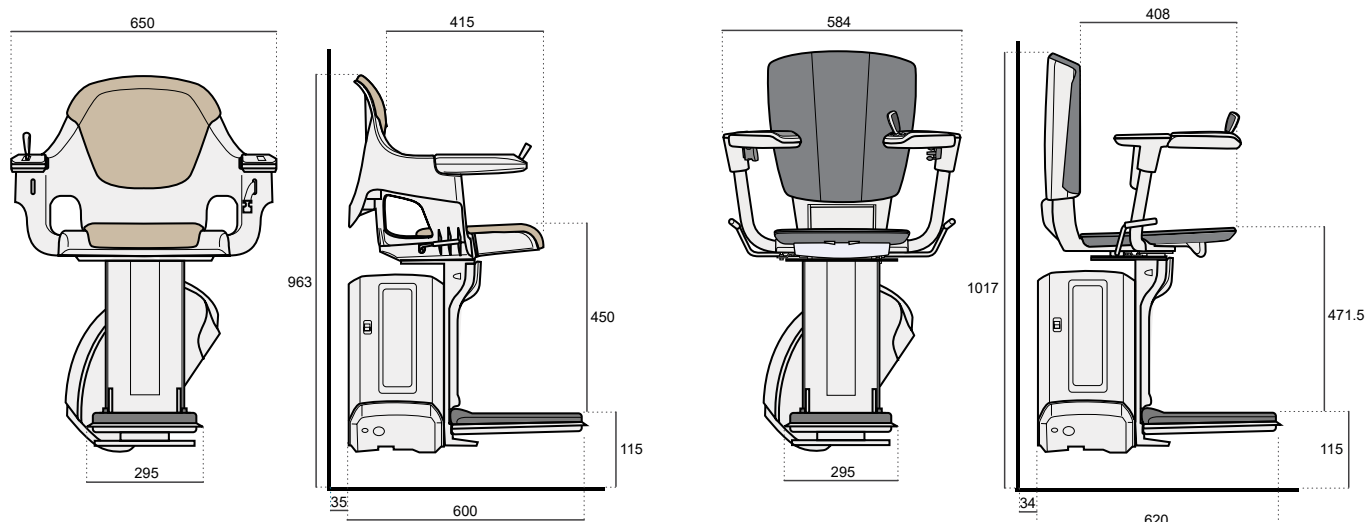

Specification

| | |
|---------------------------------|--|
| Speed: | Max 0.12 m/s |
| Drive Type: | Rack and pinion |
| Motor Wattage: | 280 W |
| Weight Capacity: | Standard: max 125 kg Optional: max 146 kg |
| Batteries: | 2 x 12V batteries; total 24V |
| Operation: | Joystick control as standard |
| Staircase Incline: | 28° up to 53° (28° up to 45° with 146 kg option) |
| Certification: | Machine Directive 2006/42/EG BS EN 81-40 |
| Automatic Stop: | Yes |
| Footrest: | Yes |
| Retractable Safety Belt: | Yes |

About Access BDD

30 YEARS OF EXPERIENCE

For over 30 years, Access BDD have specialised in making life easier for both private and public customers.

Supplier of stairlifts, inclined platform lifts, vertical platform lifts and home elevators, Access BDD believe that the ability to move around freely shouldn't be something that is taken for granted. Through our wealth of knowledge and experience we have become one of the world's leading suppliers of accessibility products.

Through our wide array of customisable options on all of our products you can rest assured your new lift will seamlessly fit into your home or building.

Our extensive engineering heritage means our products are precisely developed to be industry-leading while conforming to all relevant safety guidelines. Our products are designed to be installed quickly and with minimum fuss.



The HomeGlide is the perfect solution for any straight staircase. I was able to install the stairlift within just a few hours – the customer was over the moon.”

When you choose an Access BDD product, you're choosing:

- Industry leading company with a wealth of experience
- Safety and reliability
- Technological innovation



For over 30 years we have specialised in making life easier for both private and public customers.



Your local Access BDD dealer is:

